

# See in the Dark.

Reliable Inspection also of  
the Dark Side of Color Space.

Color Control and  
Color Measurement

## SPECTRO-3-SL / -SLE / -SLA Series True Color Sensors



## SPECTRO-3-SL Series / SPECTRO-3-SLE Series / SPECTRO-3-SLA Series Color Sensors "True Color" Slim Line / Slim Line Extended / Slim Line Analog

### SPECTRO-3-SL Series

Color sensors of the SPECTRO-3-SL series can be "taught" up to three colors. Tolerances can be specified for each of the taught colors. In "XY INT - 2D" or "siM - 2D" mode the tolerances represent a color cylinder in space. In "XY INT - 3D" or "siM - 3D" mode the tolerances represent a color sphere in space.

Color evaluation according to siM is based on the Lab calculation method. All modes can be used in combination with several operating modes, e.g. "FIRST HIT" and "BEST HIT". Raw data are represented with 12 bit resolution. The maximum scan frequency is 85 kHz.

### SPECTRO-3-SLE Series

Color sensors of the SPECTRO-3-SLE series can be "taught" up to 31 colors that are directly output, and up to 64 colors that are output by way of grouping. Tolerances can be specified for each of the taught colors. In "XY INT - 2D" or "siM - 2D" mode the tolerances represent a color cylinder in space. In "XY INT - 3D" or "siM - 3D" mode the tolerances represent a color sphere in space. Color evaluation according to siM is based on the Lab calculation method. All modes can be used in combination with several operating modes, e.g. "FIRST HIT" and "BEST HIT". Raw data are represented with 12 bit resolution.

As a special feature the sensor can be taught two parameter sets that are completely independent of each other. Input IN0 is used to inform the sensor which parameter set should be used.

Color detection either operates continuously or is started through an external PLC trigger signal. The respective detected color either is provided as a binary code at the five digital outputs or can be sent directly to the outputs, if only up to five colors are to be detected.

Through input IN0 the color sensor can be taught up to 31 colors (max. 64 colors in group mode). For this purpose the corresponding evaluation mode must be set with the software.

### SPECTRO-3-SLA Series

When the integrated light source of the SPECTRO-3-SLA color sensor is activated the sensor detects the radiation that is diffusely reflected from the object. As a light source the SPECTRO-3-SLA color sensor uses a white light LED with adjustable transmission power. An integrated 3-fold receiver for the red, green, and blue content of the light that is reflected from the object, or the light that is emitted by a "self-luminous object", is used as a receiver.

The sensor features three analog outputs that either provide the red, green, blue contents or the calculated color coordinates (X, Y, INT or s, i, M) as 0...+10V or 4...20mA.

## Windows® PC Software SPECTRO3-SL-Scope, SPECTRO3-COMFORT-Scope, SPECTRO3-SLE-Scope and SPECTRO3-SLA-Scope

### SPECTRO3-SL-Scope Software

Up to three colors can be taught with the SPECTRO3-SL-Scope Windows interface, using the familiar BEST HIT, MINIMAL DISTANCE, FIRST HIT evaluation modes in the siM and xyINT color spaces. A COL2 mode and three other modes for color mark detection (THDRG, THDRB and THDGB) also are available.

### SPECTRO3-COMFORT-Scope Software

The SPECTRO3-COMFORT-Scope software makes it much easier to parameterise the color sensor because the operator is step by step guided through the teach process, using an evaluation mode that according to experience is excellently suited for most applications.

### SPECTRO3-SLE-Scope Software

The SPECTRO3-SLE-Scope operating software allows the teaching of up to 64 colors with a maximum of 31 color groups. The data rate has been extended to 460 kbaud, and the software reads the sensor's firmware version and serial number.

### SPECTRO3-SLA-Scope Software

Depending on the selected color space the xyINT, siM- and RGB values can be assigned to the three analog outputs with the SPECTRO3-SLA-Scope software. The outputs can be configured as voltage outputs (0V...+10V) and current outputs (4mA ... 20mA). The digital input in addition to the "freezing" of analog values (at a rising signal edge) also can be used for referencing. For this all the analog outputs are set to +5V, and with the zoom function a color change can be amplified in steps with a maximum factor of 128 around this reference value.

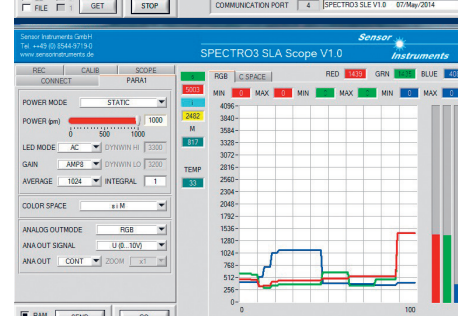
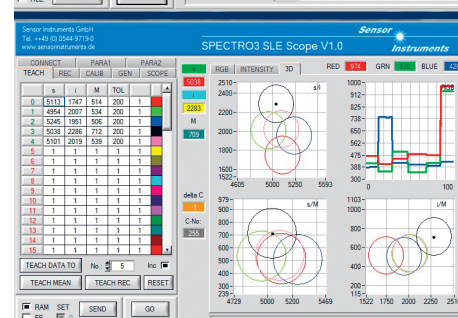
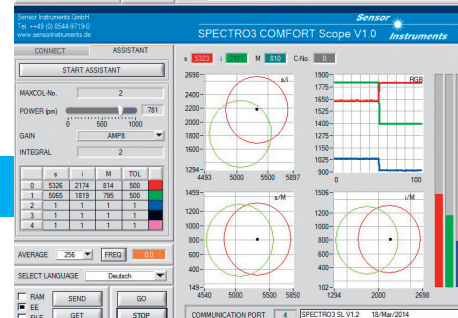
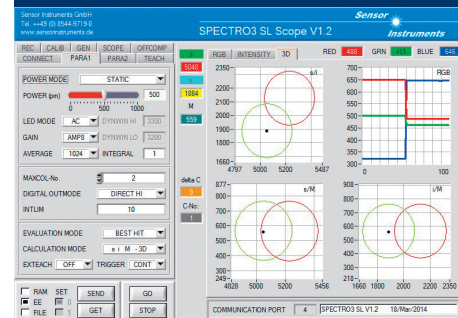
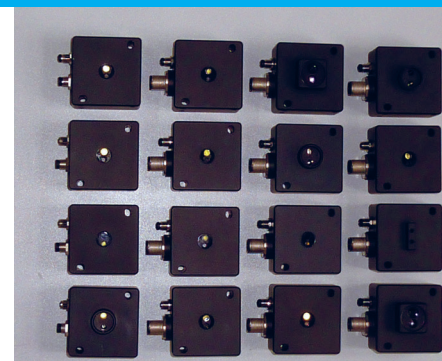

Application example:

## Groove checking at a metal rod

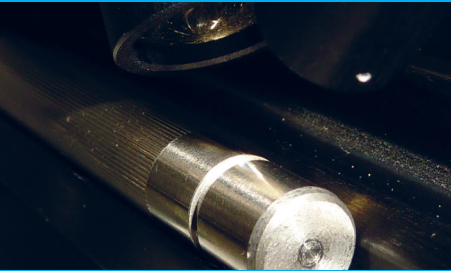

The presence of a groove at a metal rod should be checked. For this application a color sensor of type SPECTRO-3-FIO-SL is used in combination with through-beam fiber optics of type R-S-R2.1-(6x1)-1200-67° and an optical frontend of type KL-8-R2.1. The two fiber optics ends are arranged in V-shape. The distance from the object surface is approx. 11 mm.

Application example:

## LED color checking at interior components

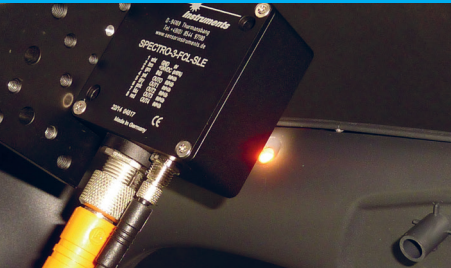

The color and the intensity of LEDs that are integrated in plastic components for the interior should be checked. This application uses a color sensor of type SPECTRO-3-FCL-SLE. The sensor has a distance from the LED of approx. 25 mm.

Application example:

## Color checking of a textile web



The color of a textile web is checked by means of a color sensor of type SPECTRO-3-FCL-SLE. The distance between sensor and textile web surface is approx. 25 mm.

Application example:

## Color checking of lipsticks



Color checking is performed by a SPECTRO-3-FIO-SLE in combination with fiber optics of type R-S-A2.0-(2.5)-1200-67° and an optical frontend of type KL-3-A2.0. The light spot is directed at an angle onto the surface to be checked in order to suppress direct reflection. The distance is about 13 mm, and the spot size is approx. 1.5 mm.

Application example:

## Color checking of a coated metal surface



In this application the presence of a coating on a metal surface should be checked. With a color sensor of type SPECTRO-3-DIL-SLE the presence of this coating can be perfectly detected from a distance of approx. 20 mm.

Application example:

## Color gradient checking of a plastic wire



The color values of a plastic wire should be provided as analog values (4 ... 20 mA) at the sensor's output. For this application a SPECTRO-3-FIO-SLA is used in combination with reflective fiber optics of type R-S-A3.0-(3.0)-1200-67° and an optical frontend of type KL-9-A3.0. The distance between optical frontend and plastic wire surface is approx. 11 mm with a light spot diameter of approx. 1.5 mm.

# SPECTRO-3-...-SL

## Color sensors of SPECTRO-3-SL Series (Slim Line)

TYPE	OBJECT DISTANCE/ MEASURING RANGE (TYP.)	SIZE OF LIGHT SPOT/ DETECTION RANGE (AT DISTANCE, TYP.)	DIMENSIONS (LxWxH IN MM, WITHOUT CONNECTOR)	LIGHT SOURCE (TRANSMITTER)	RECEIVER	SCAN FREQUENCY	COLOR MEMORY	TEACH- BUTTON	OUTPUTS	SWITCHING STATE INDICATION	SWITCHING CURRENT	SOFTWARE/ INTERFACE
SPECTRO-3-COF-d3.0-SL	10 ... 200 mm	Ø3 mm (75 mm)	50 x 50 x 37	White light LED, super bright	RGB detector: True Color detector, „human color reception“. Color filter curves acc. to CIE1931	AC-operation: max. 28 kHz DC-operation: max. 85 kHz OFF-operation: max. 85 kHz	Non-volatile EEPROM with parameter sets for max. 3 colors (or max. 64 colors in group mode)	For external teaching of max. 3 colors (or max. 64 colors in group mode)	2x digital output: OUT0, OUT1 (0/+24V), npn-/pnp- able	2 yellow LEDs visualize the physical state of the outputs OUT0, OUT1	Max. 100 mA, short circuit proof	SPECTRO3-SL- Scope or SPECTRO3- COMFORT-Scope, RS232 (USB- and Ethernet adaptor available)
SPECTRO-3-COF-d5.0-SL	10 ... 200 mm	Ø5 mm (80 mm)	50 x 50 x 37									
SPECTRO-3-COF-d8.0-SL	10 ... 200 mm	Ø8 mm (85 mm)	50 x 50 x 37									
SPECTRO-3-DIL-SL	5 ... 50 mm	5 mm (15 mm) ... 29 mm (50 mm)	50 x 50 x 27	White light LED, super bright, diffuse								
SPECTRO-3-FCL-SL	5 ... 120 mm	5 mm (10 mm) ... 30 mm (100 mm)	50 x 50 x 27	White light LED, super bright, focused								
SPECTRO-3-POL-SL	5 ... 50 mm	3 mm (5 mm) ... 14 mm (50 mm)	50 x 50 x 27	White light LED, super bright, focused, polarization filter								
SPECTRO-3-UV-SL	1 ... 50 mm	5 mm (5 mm) ... 14 mm (50 mm)	50 x 50 x 27	UV-LED, 375 nm								
SPECTRO-3-POF-SL	1 ... 500 mm (depends on optical fiber)	Ø1 mm ... Ø20 mm (depends on optical fiber)	50 x 50 x 32.5	White light LED, super bright								
SPECTRO-3-FIO-SL	1 ... 500 mm (depends on optical fiber and frontend)	Ø0.2 mm ... Ø20 mm or 3 mm x 0.5 mm ... 48 mm x 0.15 mm (depends on optical fiber)	50 x 50 x 36	White light LED, super bright								
SPECTRO-3-FIO-UV-SL	1 ... 500 mm (depends on optical fiber and frontend)	Ø1.5 mm ... Ø3 mm or 3 mm x 0.5 mm ... 6 mm x 1 mm (depends on optical fiber)	50 x 50 x 36	UV-LED, 375 nm								
GENERAL TECHNICAL DATA	Voltage supply: +24VDC (± 10%). Current consumption: <160 mA. Transmitter control: LED mode can be switched via PC software (AC-, DC-, or OFF-operation). Switching frequency: typ. 60 kHz. Enclosure rating: IP64. Type of connector: 1x 4-pole connector M8, 1x 4-pole fem. connector Binder Series 707. Housing material: Aluminum, anodized in black. Operating temperature range: -20°C...+55°C. EMC test acc. to: DIN EN 60947-2.											

### Illustrations

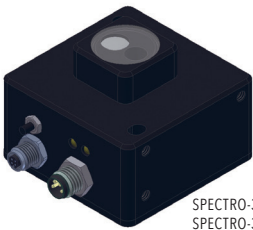

SPECTRO-3-COF-d3.0-SL  
SPECTRO-3-COF-d5.0-SL  
SPECTRO-3-COF-d8.0-SL

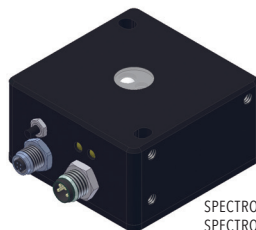

SPECTRO-3-DIL-SL  
SPECTRO-3-FCL-SL  
SPECTRO-3-POL-SL  
SPECTRO-3-UV-SL



SPECTRO-3-POF-SL

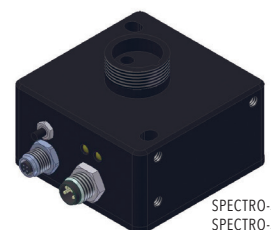

SPECTRO-3-FIO-SL  
SPECTRO-3-FIO-UV-SL

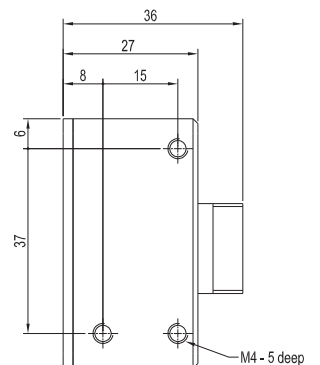
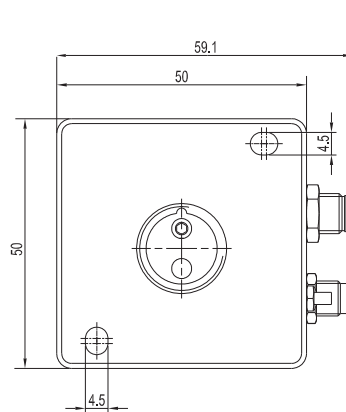
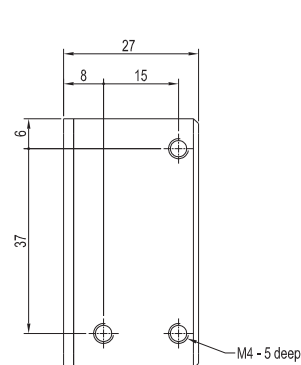
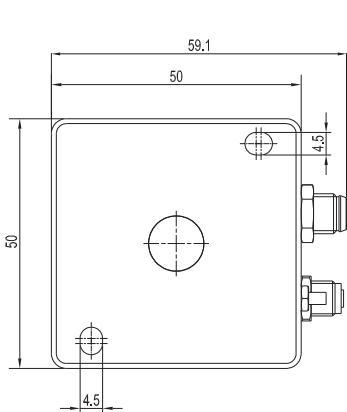
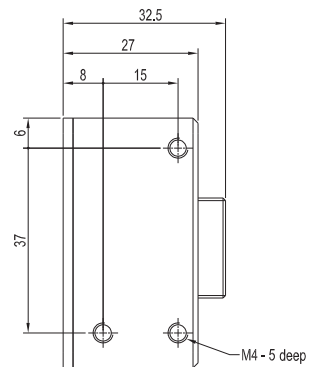
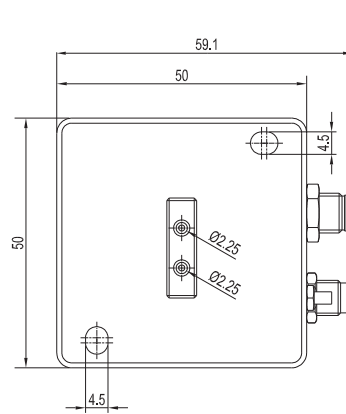
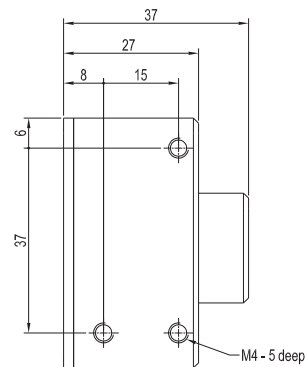
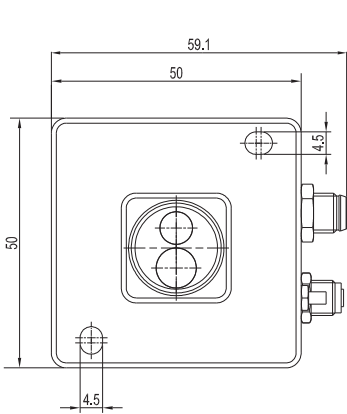

# SPECTRO-3-...-SLE

## Color sensors of SPECTRO-3-SLE Series (Slim Line Extended)

TYPE	OBJECT DISTANCE/ MEASURING RANGE (TYP.)	SIZE OF LIGHT SPOT/ DETECTION RANGE (AT DISTANCE, TYP.)	DIMENSIONS (LxWxH IN MM, WITHOUT CONNECTOR)	LIGHT SOURCE (TRANSMITTER)	RECEIVER	SCAN FREQUENCY	COLOR MEMORY	INPUTS	OUTPUTS	SWITCHING CURRENT	SOFTWARE/ INTERFACE
<b>SPECTRO-3-COF-d3.0-SLE</b>	10 ... 200 mm	Ø3 mm (75 mm)	50 x 50 x 37	White light LED, super bright	RGB detector: True Color detector, „human color reception“. Color filter curves acc. to CIE1931	AC-operation: max. 20 kHz DC-operation: max. 35 kHz OFF-operation: max. 35 kHz	Non-volatile EEPROM with parameter sets for max. 31 colors (or max. 64 colors in group mode)	1x digital input: (0V/+24V)	5x digital output: OUT0 ... OUT4 (0/+24V), npn-/pnp-able	Max. 100 mA, short circuit proof	SPECTRO3-SLE- Scope or SPECTRO3- COMFORT-Scope, RS232 (USB- and Ethernet adaptor available)
<b>SPECTRO-3-COF-d5.0-SLE</b>	10 ... 200 mm	Ø5 mm (80 mm)	50 x 50 x 37								
<b>SPECTRO-3-COF-d8.0-SLE</b>	10 ... 200 mm	Ø8 mm (85 mm)	50 x 50 x 37								
<b>SPECTRO-3-DIL-SLE</b>	5 ... 50 mm	5 mm (15 mm) ... 29 mm (50 mm)	50 x 50 x 27	White light LED, super bright, diffuse							
<b>SPECTRO-3-FCL-SLE</b>	5 ... 120 mm	5 mm (10 mm) ... 30 mm (100 mm)	50 x 50 x 27	White light LED, super bright, focused							
<b>SPECTRO-3-POL-SLE</b>	5 ... 50 mm	3 mm (5 mm) ... 14 mm (50 mm)	50 x 50 x 27	White light LED, super bright, focused, polarization filter							
<b>SPECTRO-3-UV-SLE</b>	1 ... 50 mm	5 mm (5 mm) ... 14 mm (50 mm)	50 x 50 x 27	UV-LED, 375 nm							
<b>SPECTRO-3-POF-SLE</b>	1 ... 500 mm (depends on optical fiber)	Ø1 mm ... Ø20 mm (depends on optical fiber)	50 x 50 x 32.5	White light LED, super bright							
<b>SPECTRO-3-FIO-SLE</b>	1 ... 500 mm (depends on optical fiber and frontend)	Ø0.2 mm ... Ø20 mm or 3 mm x 0.5 mm ... 48 mm x 0.15 mm (depends on optical fiber)	50 x 50 x 36	White light LED, super bright							
<b>SPECTRO-3-FIO-UV-SLE</b>	1 ... 500 mm (depends on optical fiber and frontend)	Ø1.5 mm ... Ø3 mm or 3 mm x 0.5 mm ... 6 mm x 1 mm (depends on optical fiber)	50 x 50 x 36	UV-LED, 375 nm							
GENERAL TECHNICAL DATA	<b>Voltage supply:</b> +24VDC (± 10%). <b>Current consumption:</b> <160 mA. <b>Transmitter control:</b> LED mode can be switched via PC software (AC-, DC-, or OFF-operation). <b>Switching frequency:</b> typ. 35 kHz. <b>Enclosure rating:</b> IP64. <b>Type of connector:</b> 1x 4-pole connector M12, 1x 4-pole fem. connector Binder Series 707. <b>Housing material:</b> Aluminum, anodized in black. <b>Operating temperature range:</b> -20°C...+55°C. <b>EMC test acc. to:</b> DIN EN 60947-2.										

### Illustrations

Dimensions in mm

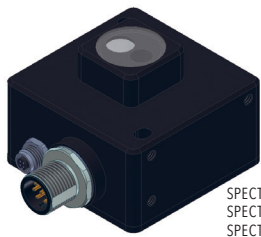

SPECTRO-3-COF-d3.0-SLE  
SPECTRO-3-COF-d5.0-SLE  
SPECTRO-3-COF-d8.0-SLE

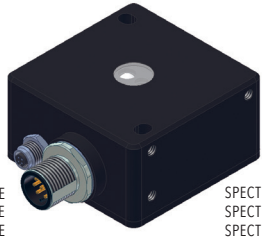

SPECTRO-3-DIL-SLE  
SPECTRO-3-FCL-SLE  
SPECTRO-3-POL-SLE  
SPECTRO-3-UV-SLE

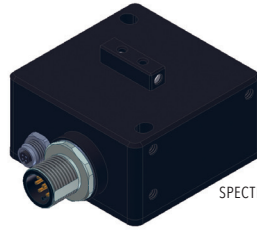

SPECTRO-3-POF-SLE

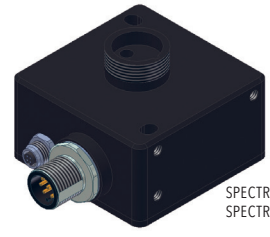

SPECTRO-3-FIO-SLE  
SPECTRO-3-FIO-UV-SLE

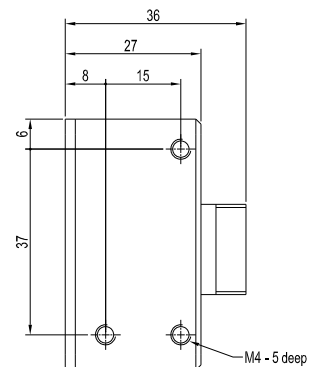
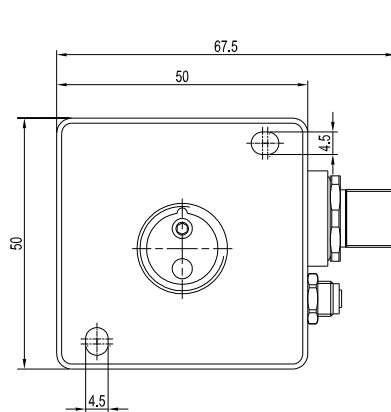
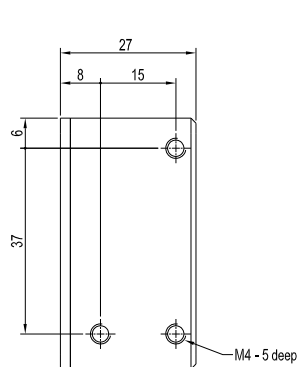
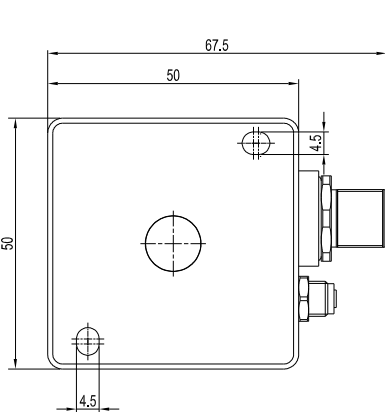
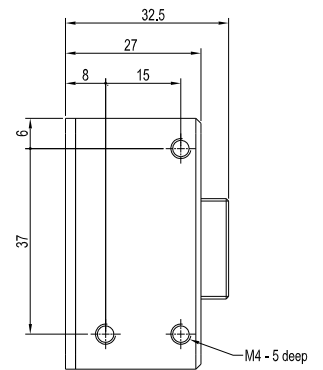
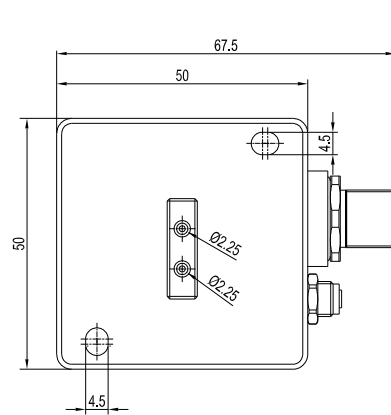
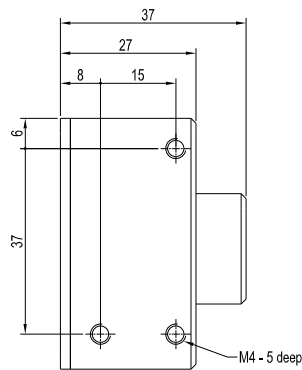
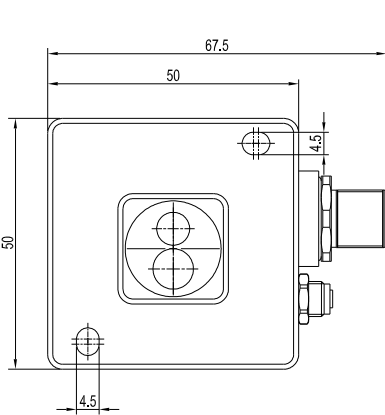

# SPECTRO-3-...-SLA

## Color sensors of SPECTRO-3-SLA Series (Slim Line Analog)

TYPE	OBJECT DISTANCE/ MEASURING RANGE (TYP.)	SIZE OF LIGHT SPOT/ DETECTION RANGE (AT DISTANCE, TYP.)	DIMENSIONS (LxWxH IN MM, WITHOUT CONNECTOR)	LIGHT SOURCE (TRANSMITTER)	RECEIVER	SCAN FREQUENCY	INPUTS	OUTPUTS	SWITCHING CURRENT	SOFTWARE/ INTERFACE
<b>SPECTRO-3-COF-d3.0-SLA</b>	10 ... 200 mm	Ø3 mm (75 mm)	50 x 50 x 37	White light LED, super bright	RGB detector: True Color detector, „human color reception“: Color filter curves acc. to CIE1931	AC-operation: max. 25 kHz DC-operation: max. 90 kHz OFF-operation: max. 90 kHz	1x digital input: (0V/+24V)	3x analog output: ANA OUT red ANA OUT green ANA OUT blue, the 3 outputs either provide the red, green, blue components or the calculated color coordinates (X, Y, INT or s, i, M) from 0...+10V or 4...20mA	Max. 100 mA, short circuit proof	SPECTRO3-SLA- Scope, RS232 (USB- and Ethernet adaptor available)
<b>SPECTRO-3-COF-d5.0-SLA</b>	10 ... 200 mm	Ø5 mm (80 mm)	50 x 50 x 37							
<b>SPECTRO-3-COF-d8.0-SLA</b>	10 ... 200 mm	Ø8 mm (85 mm)	50 x 50 x 37							
<b>SPECTRO-3-DIL-SLA</b>	5 ... 50 mm	5 mm (15 mm) ... 29 mm (50 mm)	50 x 50 x 27	White light LED, super bright, diffuse						
<b>SPECTRO-3-FCL-SLA</b>	5 ... 120 mm	5 mm (10 mm) ... 30 mm (100 mm)	50 x 50 x 27	White light LED, super bright, focused						
<b>SPECTRO-3-POL-SLA</b>	5 ... 50 mm	3 mm (5 mm) ... 14 mm (50 mm)	50 x 50 x 27	White light LED, super bright, focused, polarization filter						
<b>SPECTRO-3-UV-SLA</b>	1 ... 50 mm	5 mm (5 mm) ... 14 mm (50 mm)	50 x 50 x 27	UV-LED, 375 nm						
<b>SPECTRO-3-POF-SLA</b>	1 ... 500 mm (depends on optical fiber)	Ø1 mm ... Ø20 mm (depends on optical fiber)	50 x 50 x 32.5	White light LED, super bright						
<b>SPECTRO-3-FIO-SLA</b>	1 ... 500 mm (depends on optical fiber and frontend)	Ø0.2 mm ... Ø20 mm or 3 mm x 0.5 mm ... 48 mm x 0.15 mm (depends on optical fiber)	50 x 50 x 36	White light LED, super bright						
<b>SPECTRO-3-FIO-UV-SLA</b>	1 ... 500 mm (depends on optical fiber and frontend)	Ø1.5 mm ... Ø3 mm or 3 mm x 0.5 mm ... 6 mm x 1 mm (depends on optical fiber)	50 x 50 x 36	UV-LED, 375 nm						
GENERAL TECHNICAL DATA	<b>Voltage supply:</b> +24VDC (± 10%). <b>Current consumption:</b> <160 mA. <b>Transmitter control:</b> LED mode can be switched via PC software (AC-, DC-, or OFF-operation). <b>Analog band width:</b> typ. 90 kHz (-3dB). <b>Enclosure rating:</b> IP64. <b>Type of connector:</b> 1x 4-pole connector M12, 1x 4-pole fem. connector Binder Series 707. <b>Housing material:</b> Aluminum, anodized in black. <b>Operating temperature range:</b> -20°C...+55°C. <b>EMC test acc. to:</b> DIN EN 60947-2.									

### Illustrations

Dimensions in mm

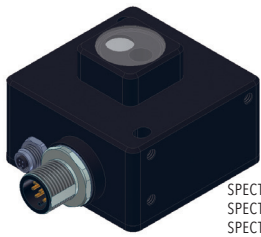

SPECTRO-3-COF-d3.0-SLA  
SPECTRO-3-COF-d5.0-SLA  
SPECTRO-3-COF-d8.0-SLA

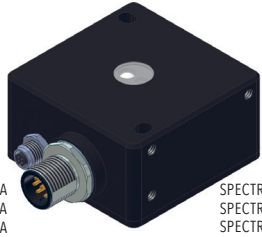

SPECTRO-3-DIL-SLA  
SPECTRO-3-FCL-SLA  
SPECTRO-3-POL-SLA  
SPECTRO-3-UV-SLA

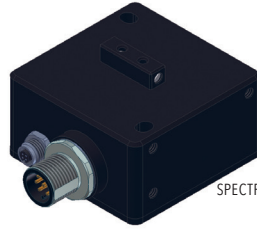

SPECTRO-3-POF-SLA

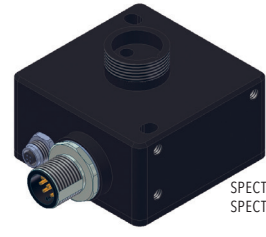



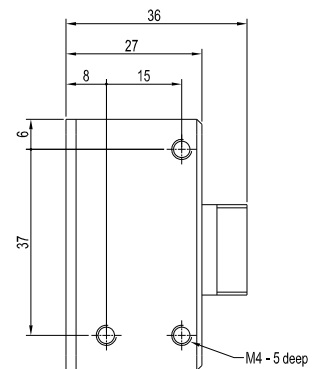
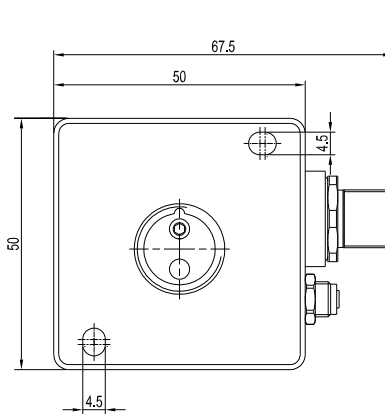
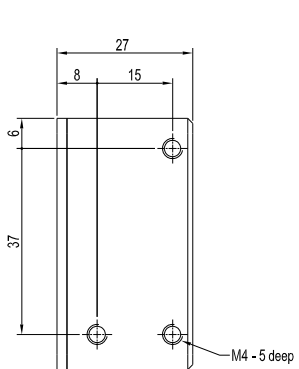
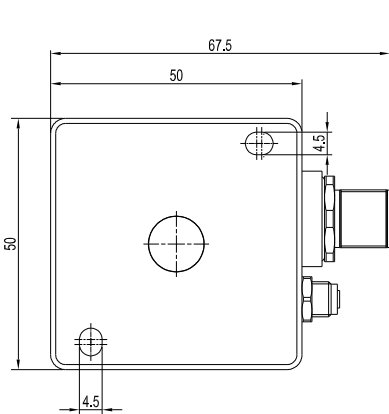
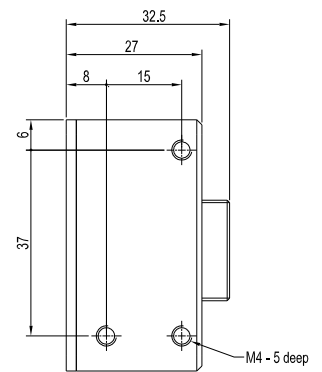
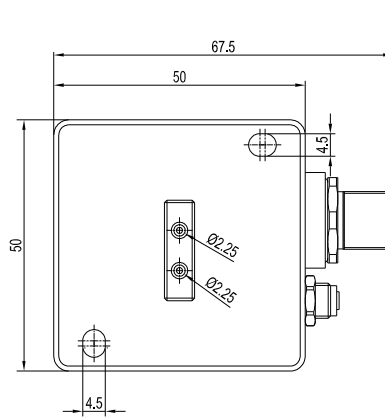
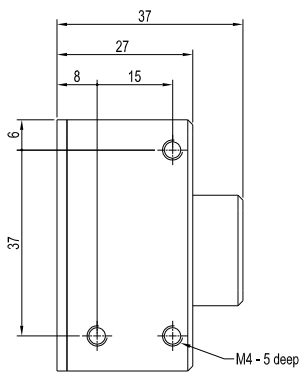
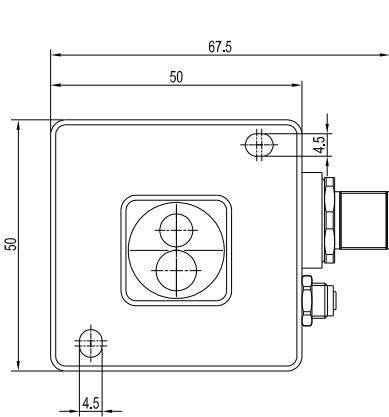

SPECTRO-3-FIO-SLA  
SPECTRO-3-FIO-UV-SLA

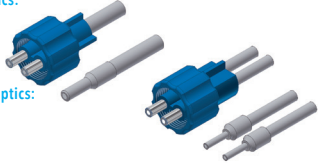

# FIO Series

## Glass fiber optics (reflected light or transmitted light) and optical frontends

Only a few types are shown here. Find the **COMPLETE ASSORTMENT** and **ALL SPECIFICATIONS** on our Website or in the catalog for FIO Series and POF Series.

OPTICAL FIBER HEAD TYPES, E.G.		
<p><b>Reflected light fiber optics:</b> R-S-A1.1-(1.5)-... R-S-A2.0-(2.5)-... R-S-A3.0-(3.0)-...</p> 	<p><b>Reflected light fiber optics:</b> T-S-M5.0-(5.0)-... T-S-M6.0-(6.0)-... T-S-M8.0-(8.0)-...</p> 	<p><b>Reflected light fiber optics:</b> R-S-R1.1-(3x0.5)-... R-S-R2.1-(6x1)-...</p> 
<p><b>Transmitted light fiber optics:</b> D-S-A1.1-(1.5)-... D-S-A2.0-(2.5)-... D-S-A3.0-(3.0)-...</p> 		

OPTICAL FRONTENDS, E.G.		
KL-1-A2.0	KL-2-A2.0	KL-3-A2.0 KL-4-A1.1 KL-5-R1.1 KL-8-R2.1 KL-9-A3.0
KL-3/90°-A2.0 KL-8/90°-R2.1	KL-90-A2.0	KL-M8-A1.1
KL-M12-A1.1 KL-M12-A2.0 KL-M12-A3.0 KL-M12-R1.1	KL-M12-XL-A1.1 KL-M12-XL-A2.0 KL-M12-XL-R1.1	KL-M12/90°-XL-A2.0
KL-M18-A1.1 KL-M18-A2.0 KL-M18-A3.0 KL-M18-M5.0 KL-M18-M6.0 KL-M18-M8.0 KL-M18-R1.1 KL-M18-R2.1	KL-M18-XL-A1.1 KL-M18-XL-A2.0 KL-M18-XL-A3.0 KL-M18-XL-M5.0 KL-M18-XL-M6.0 KL-M18-XL-M8.0 KL-M18-XL-R1.1 KL-M18-XL-R2.1	KL-M18-XL-0°/(17°-60°)-30-M5.0
KL-M34-A1.1 KL-M34-A2.0 KL-M34-A3.0 KL-M34-M5.0 KL-M34-M6.0 KL-M34-M8.0 KL-M34-R1.1 KL-M34-R2.1	KL-M34-XL-A1.1 KL-M34-XL-A2.0 KL-M34-XL-A3.0 KL-M34-XL-M5.0 KL-M34-XL-M6.0 KL-M34-XL-M8.0 KL-M34-XL-R1.1 KL-M34-XL-R2.1	KL-M34/62-A1.1 KL-M34/62-A2.0 KL-M34/62-A3.0 KL-M34/62-R1.1 KL-M34/62-R2.1
KL-D-0°/2.5°-300-A2.0	KL-D-0°/45°-30-A2.0 KL-D-0°/45°-30-A3.0	KL-D-6°-200-A2.0
KL-D-10°-45-POL-A3.0	KL-D-14°-84-A2.0	KL-D-17°-49-A2.0
KL-D-20°-31-A2.0	KL-D-28°-26-A2.0	KL-D-30°-23-A2.0
KL-D-40°-13-A2.0	KL-D-M12-0°/30°-9-A2.0 KL-D-M12-0°/30°-9-A3.0	KL-D-M12-XL-0°/30°-30-A2.0

# POF Series

## Plastic fiber optics (reflected light or transmitted light)

OPTICAL FIBER HEAD TYPES, E.G.		
POF-R-32-d3-(0.5)-2000	POF-R-35-M4/d3-(0.5)-2000	POF-R-40-M6x0.75/d4-(1.0)-2000
POF-R-55-M4/M3-(0.5)-2000	POF-R-75-d6/d4-(1.0)-2000	POF-R/90-25-d3/d1.5-(0.5)-2000
POF-R-HT-M6x0.75/d4-(1.0)-2000-VA	POF-D-100-M3/d2-(0.5)-2000	POF-SPX2-d2.2-(1.0)-(Length)



## Manufacturer

Sensor Instruments Entwicklungs- und Vertriebs GmbH  
Schlinding 11  
D-94169 Thurmansbang/Germany  
Phone +49 (0) 8544.97 19-0  
Fax +49 (0) 8544.97 19-13  
info@sensorinstruments.de  
www.sensorinstruments.de

## Further product lines



Distance measurement  
and positioning

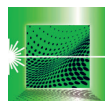

Surface inspection  
and counting



Product marking  
and product tracking



Fiber optics  
and accessories

Presented by

